

Compressed air industrial stirrers model series PM 120/1000

General specifications

- All-stainless steel housing
- Operating pressure 3-6 bar
- Air consumption 1380 L/min. at 6 bar
- Clockwise rotation
- ATEX certification



Basic models include

- Continuously adjustable speed control valve
- Plug-in connector for DN 7.8
- Silencer

Types of mixing

- Homogenising
- Suspending
- Heat exchange
- Dispersing

Speed range

- Low to medium



Type	PM 120/1000-V
Description	With circular flange
Viscosity	80000 mPas
Power output	1,2 kW
Volume	1500 L
No-load speed	1000 rpm
Minimum operation speed	400 rpm
Torque	19 Nm
ATEX	Ex II 2G Ex h IIC T4 Gb
Code-No.	40 26446 00830 7

All technical pertaining to 6 bar. Viscosity data to be considered as guidelines.

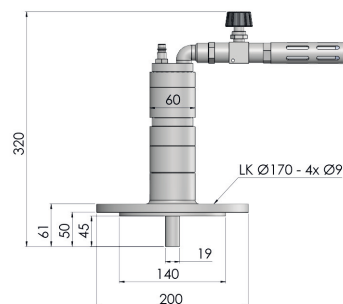

All dimensions in mm.