

Compressed air industrial stirrers model series PM 120/600

General specifications

- All-stainless steel housing
- Operating pressure 3-6 bar
- Air consumption 1380 L/min. at 6 bar
- Clockwise rotation
- ATEX certification



Basic models include

- Continuously adjustable speed control valve
- Plug-in connector for DN 7.8
- Silencer

Types of mixing

- Homogenising
- Suspending
- Heat exchange

Speed range

- Low to medium



Type	PM 120/600-V
Description	With circular flange
Viscosity	100000 mPas
Power output	1.2 kW
Volume	1500 L
No-load speed	600 rpm
Minimum operation speed	200 rpm
Torque	38 Nm
ATEX	Ex II 2G Ex h IIC T4 Gb
Code-No.	40 26446 00829 1

All technical pertaining to 6 bar. Viscosity data to be considered as guidelines.

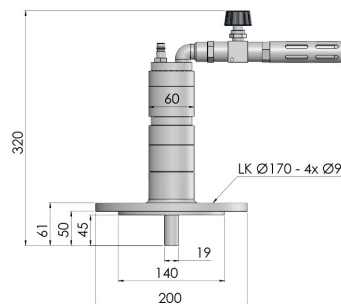

All dimensions in mm.