





## Magnetic stirrer couplings BUK G model series

### The G design (vacuum-proof, pressure-resistant up to 700 bar)

Threaded magnetic stirrer couplings are the first choice for stirring processes under high to very high pressure. This design can be used for applications up to 200 bar (in the variant made of high-temperature-resistant alloy A-286, 1.4980 even up to 700 bar).

Variants in special materials such as Hastelloy C22, C276, B3 are available on request.

### Types of mixing

-  Homogenising
-  Dispersing
-  Suspending
-  Gassing

### Pressure

-  Vacuum / pressure up to 700 bar



Type	BUK K50G Mini	BUK K50G Mini HP	BUK K90G
Connection	Thread M18x1	Thread M18x1	Thread M30x2
Temperature max.	250 °C	250 °C	300 °C
Pressure max.	200 bar	700 bar	200 bar
Sealings*	O-ring FFKM or cutting ring HC22	O-ring FFKM or cutting ring HC22	O-ring FFKM or cutting ring HC22
Material	1.4435 AISI 316L	1.4980 Alloy A-286	1.4435 AISI 316L
Speed max.	2500 rpm	2500 rpm	2500 rpm
Torque	50 Ncm	50 Ncm	90 Ncm
Volume max.	1000 ml	1000 ml	10000 ml
Bearings	Ball bearings stainless steel	Ball bearings stainless steel	Ball bearings stainless steel
Reed contact and speed sensor	Yes	Yes	Yes
Gas flush connection	-	-	-
Drive motor	-	-	-
Code-No.	40 26446 00189 6	40 26446 00187 2	40 26446 00198 8

\*Seal not included with delivery. Drive shaft supplied with 6 mm external square stub.

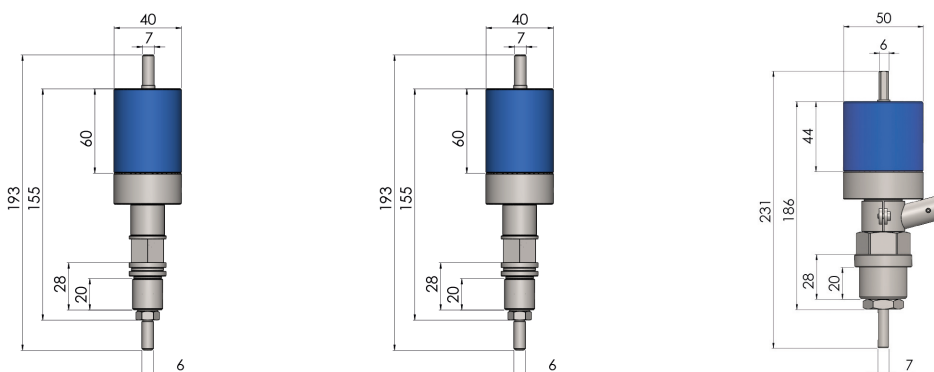

All dimensions in mm.